

SigmaTel, Inc.

Integrating Mixed-Signal Solutions

PRELIMINARY

STAC9780/82

Low Cost AC'97 Codec

GENERAL DESCRIPTION:

SigmaTel's **STAC9780/82** are general-purpose 18-bit stereo, full duplex, audio codecs built around the analog component specification of AC'97. The **STAC9780/82** incorporate *SigmaTel's* proprietary Sigma-Delta technology to achieve a DAC SNR in excess of 90dB and line through SNR of greater than 95dB. The DACs, ADCs, and mixer are integrated with analog I/Os, which include three analog line-level stereo inputs, one analog line-level mono input, and one stereo output channel. Also included is *SigmaTel's* 3D stereo enhancement (**SS3D**) for increased speaker separation when using typical low-cost PC speakers. The **STAC9780/82** communicate via the five-wire AC-Link interface with any AC-Link capable controller or advanced core logic chip-set. Packaged in a 28-pin SSOP, the **STAC9780/82** can be placed on motherboards, daughter boards, add-on cards or docking stations. Choose between the **STAC9780** with its CD_GROUND pin, or the **STAC9782** and its X_OUT pin depending on the application.

FEATURES:

- High performance $\Sigma\Delta$ technology
- Energy saving power down modes
- 18-bit full duplex stereo ADC, DACs
- AC-Link protocol compliance
- Low-noise differential CDROM input
- SigmaTel Surround (SS3D) Stereo Enhancement
- Five analog line-level inputs
- 28-pin SSOP
- SNR > 90 dB through Mixer and DAC
- +3.3V or +5V DVdd operation with +5V

Part Number	PACKAGE	TEMPERATURE RANGE	SUPPLY RANGE
STAC9780S	28-pin SSOP	0 ^o C to +70 ^o C	DVdd = 3.3V or 5V, AVdd = 5V
STAC9782S	28-pin SSOP	0 ^o C to +70 ^o C	DVdd = 3.3V or 5V, AVdd = 5V

SigmaTel reserves the right to change specifications without notice

TABLE OF CONTENTS:

GENERAL DESCRIPTION:	1
TABLE OF CONTENTS:	2
TABLE OF CONTENTS – FIGURES	3
1. OVERVIEW	5
2. PIN/SIGNAL DESCRIPTIONS	7
2.1 DIGITAL I/O	7
2.2 ANALOG I/O	7
3. AC-LINK	8
3.1 CLOCKING	9
3.2 RESET	9
4. DIGITAL INTERFACE	9
4.1 AC-LINK DIGITAL SERIAL INTERFACE PROTOCOL	9
4.2 AC-LINK AUDIO OUTPUT FRAME (SDATA_OUT)	10
4.2.2 AC-Link Audio Input Frame (SDATA_IN)	12
4.3 AC-LINK LOW POWER MODE	14
4.3.1 Waking up the AC-Link	15
5. STAC9780/82 MIXER	15
5.1 MIXER INPUT	16
5.2 MIXER OUTPUT	16
5.3 PROGRAMMING REGISTERS:	16
5.3.1 Reset Register (Index 00h)	17
5.3.2 Play Master Volume Registers (Index 02h and 06h)	17
5.3.3 Analog Mixer Input Gain Registers (Index 0Ch - 18h)	17
5.3.4 Record Select Control Register (Index 1Ah)	17
5.3.5 Record Gain Registers (Index 1Ch)	18
5.3.6 General Purpose Register (Index 20h)	19
5.3.7 3D Control Register (Index 22h)	19
5.3.8 Powerdown Control/Status Register (Index 26h)	19
5.3.9 Revision Code Register (Index 6Ah)	20
5.3.10 Analog Special Register (Index 6Eh)	20
5.3.11 Vendor ID1 and ID2 (Index 7Ch and 7Eh)	20
6. LOW POWER MODES	20
7. TESTABILITY	22
8. AC TIMING CHARACTERISTICS	22
8.1 COLD RESET	22
8.2 WARM RESET	22
8.3 CLOCKS	23
8.4 DATA SETUP AND HOLD	24
8.5 SIGNAL RISE AND FALL TIMES	25
8.6 AC-LINK LOW POWER MODE TIMING	26
8.7 ATE TEST MODE	27
9. ELECTRICAL SPECIFICATIONS: ...	28
9.1 ABSOLUTE MAXIMUM RATINGS:	28
9.2 RECOMMENDED OPERATING CONDITIONS	28
9.3 POWER CONSUMPTION	28
9.4 AC-LINK STATIC DIGITAL SPECIFICATIONS	29
9.5 STAC9780/82 +5V ANALOG PERFORMANCE CHARACTERISTICS	29
APPENDIX A	31
APPENDIX B	32
- NOTES -	33
- NOTES -	34

TABLE OF CONTENTS – TABLES

Table 1. Pin Designations	4
Table 2. Digital Signal List	7
Table 3. Analog Signal List	7
Table 4. Filtering and Voltage References	8
Table 5. Power Signal List STAC9780/82	8
Table 6. Mixer Functional Connections	16
Table 7. Programming Registers	16
Table 8. Play Master Volume Register	17
Table 9. Analog Mixer Input Gain Register	17
Table 10. Record Select Control Registers	18
Table 11. Record Gain Registers	18
Table 12. General Purpose Register	19
Table 13. 3D Control Registers	19
Table 14. Powerdown Status Registers	20
Table 15. Low Power Modes	21
Table 16. Cold Reset	22
Table 17. Warm Reset	23
Table 18. Clocks	23
Table 19. Data Setup and Hold	24
Table 20. Signal Rise and Fall Times	25
Table 21. AC-Link Low Power Mode Timing	26
Table 22. ATE Test Mode	27
Table 23. Operating Conditions	28
Table 24. Power Consumption	28
Table 25. AC-Link Static Specifications	29
Table 26. Analog Performance Characteristics	29

Table of Contents – Figures

Figure 1. Package Specifications	4
Figure 2. STAC9780/82 Block Diagram	5
Figure 3. Connection Diagram	6
Figure 4. AC-Link to its companion controller	8
Figure 5. AC'97 Standard Bi-directional Audio Frame	10
Figure 6. AC-Link Audio Output Frame	10
Figure 7. Start of an Audio Output Frame	11
Figure 8. STAC9780/82 Audio Input Frame	13
Figure 9. Start of an Audio Input Frame	13
Figure 10. STAC9780/82 Powerdown Timing	14
Figure 11. STAC9780/82 Mixer Functional Diagram	15
Figure 12. Example of STAC9780/82 Powerdown/Powerup flow	211
Figure 13. STAC9780/82 Powerdown/Powerup flow with analog still alive	211
Figure 14. Cold Reset	22
Figure 15. Warm Reset	22
Figure 16. Clocks	23
Figure 17. Data Setup and Hold	24
Figure 18. Signal Rise and Fall Times	25
Figure 19. AC-Link Low Power Mode Timing	26
Figure 20. ATE Test Mode	27

Figure 1. Package Specifications

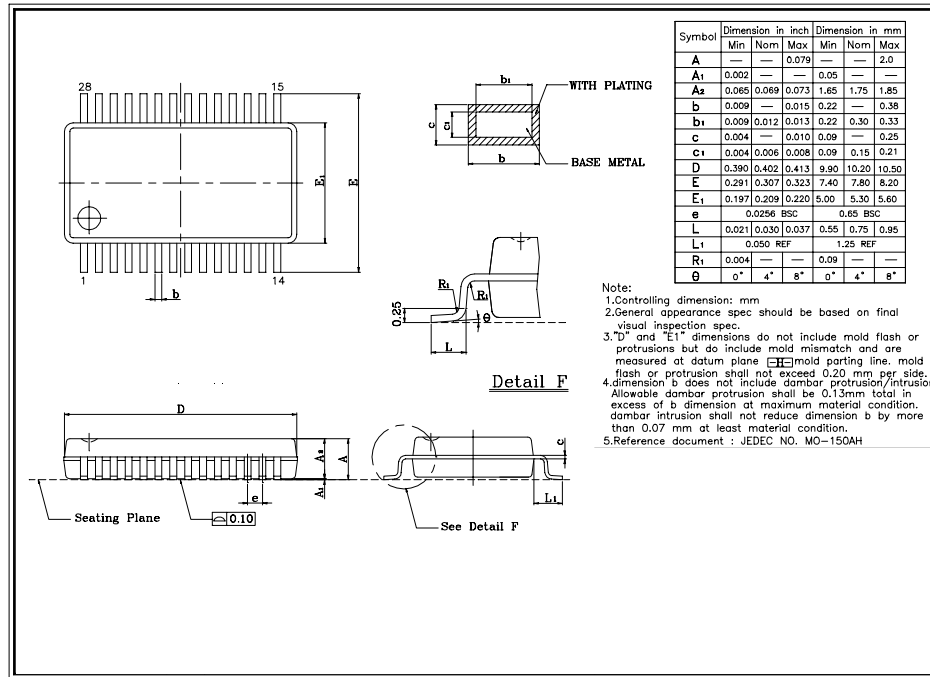

Table 1. Pin Designations

STAC9780			
Pin #	Signal Name	Pin #	Signal Name
1	DVdd1	28	AVss2
2	DVss1	27	AVdd2
3	XTL_IN	26	LINE_OUT_R
4	SDATA_OUT	25	LINE_OUT_L
5	BIT_CLK	24	CAP2
6	DVss2	23	AFILT2
7	SDATA_IN	22	AFILT1
8	DVdd2	21	Vref
9	SYNC	20	LINE_IN_R
10	RESET#	19	LINE_IN_L
11	AVdd1	18	MIC
12	AVss1	17	CD_R
13	AUX_L	16	CD_GND
14	AUX_R	15	CD_L

STAC9782			
Pin #	Signal Name	Pin #	Signal Name
1	DVdd1	28	AVss2
2	DVss1	27	AVdd2
3	XTL_IN	26	LINE_OUT_R
4	XTL_OUT	25	LINE_OUT_L
5	SDATA_OUT	24	CAP2
6	BIT_CLK	23	AFILT2
7	DVss2	22	AFILT1
8	SDATA_IN	21	Vref
9	DVdd2	20	LINE_IN_R
10	SYNC	19	LINE_IN_L
11	RESET#	18	MIC
12	AVdd1	17	CD_R
13	AVss1	16	CD_L
14	AUX_L	15	AUX_R

denotes active low

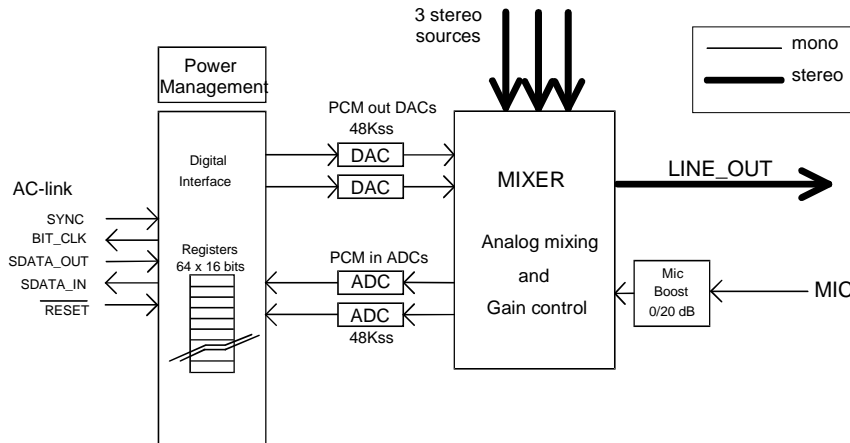

Figure 2. STAC9780/82 Block Diagram

1. Overview

The **STAC9780/82** block diagram is illustrated above. It provides a fixed 48 kHz sample rate D-A & A-D conversion, mixing, and analog processing. The digital interface communicates with the AC'97 controller via the five-wire AC-Link and contains the 64-word by 16-bit registers. The two DACs convert the digital stereo PCM-out content to audio. The MIXER block combines the PCM_OUT with any analog sources, to drive the LINE_OUT outputs. The two fixed 48 kHz sample rate ADC's provide record capability for any mix of mono or stereo sources, and deliver a digital stereo PCM-in signal back to the AC-Link. All ADC's and DAC's operate at 18-bit resolution.

The **STAC9780/82** is designed primarily to support stereo, 2-speaker audio. Also, the **STAC9780/82** provides for a stereo enhancement feature, *SigmaTel Surround 3D or SS3D*. *SS3D* provides the listener with several options for improved speaker separation beyond the normal 2-speaker arrangement.

Together, with the logic component (controller or advanced core logic chip-set) of AC'97, the **STAC9780/82** is SoundBlaster® and Windows Sound System® compatible. SoundBlaster® is a registered trademark of Creative Labs. Windows® is a registered trademark of Microsoft Corporation.

Figure 3. Connection Diagram

See Appendix A for an alternative connection diagram when using separate supplies.
See Appendix B for specific connection requirements prior to operation.

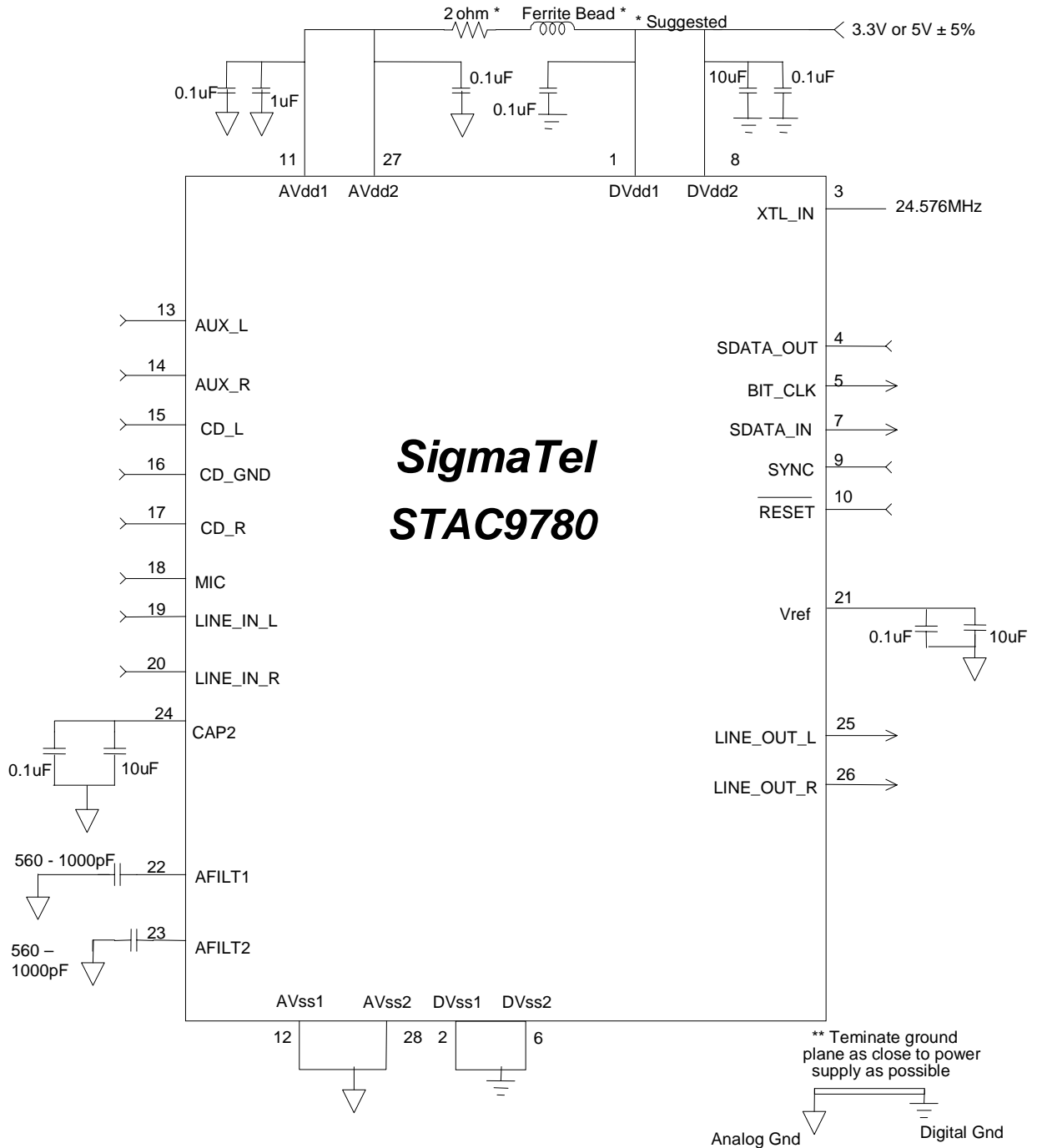

2. PIN/SIGNAL DESCRIPTIONS

2.1 Digital I/O

These signals connect the **STAC9780/82** to its AC'97 controller counterpart, and an external crystal.

Table 2. Digital Signal List

Signal Name	Type	Description
$\overline{\text{RESET}}$	I	AC'97 Master H/W Reset
XTL_IN	I	24.576 MHz Crystal or external clock source
XTL_OUT	O	STAC9782 Only
SYNC	I	48 kHz fixed rate sample sync
BIT_CLK	O	12.288 MHz serial data clock
SDATA_OUT	I	Serial, time division multiplexed, AC'97 input stream
SDATA_IN	O	Serial, time division multiplexed, AC'97 output stream

2.2 Analog I/O

These signals connect the **STAC9780/82** to analog sources and sinks, including microphones and speakers.

Table 3. Analog Signal List

Signal Name	Type	Description
MIC	I	Desktop Microphone Input
LINE_IN_L	I	Line In Left Channel
LINE_IN_R	I	Line In Right Channel
CD_L	I	CD Audio Left Channel
CD_GND	I	CD Audio Analog Ground (STAC9780 Only)
CD_R	I	CD Audio Right Channel
AUX_L	I	Aux Left Channel
AUX_R	I	Aux Right Channel
LINE_OUT_L	O	Line Out Left Channel
LINE_OUT_R	O	Line Out Right Channel

* Note: any unused input pins should be tied together and connected to ground with a capacitor (0.1 uF suggested), except the MIC1 input which requires it's own 0.1 uF capacitor to ground if not used.

1.3 Filter/References/GPIO

These signals are connected to resistors, capacitors, specific voltages, or provide general purpose I/O.

Table 4. Filtering and Voltage References

Signal Name	Type	Description
Vref	O	Reference Voltage
AFILT1	O	Anti-Aliasing Filter Cap - ADC channel
AFILT2	O	Anti-Aliasing Filter Cap - ADC channel
CAP2	O	ADC reference Cap

1.4 Power and Ground Signals

Table 5. Power Signal List STAC9780/82

Signal Name	Type	STAC9780/82	STAC9780/82
AVdd1	I	Analog Vdd = 5.0V	Analog Vdd = 3.3V
AVdd2	I	Analog Vdd = 5.0V	Analog Vdd = 3.3V
AVss1	I	Analog Gnd	Analog Gnd
AVss2	I	Analog Gnd	Analog Gnd
DVdd1	I	Digital Vdd = 5.0V or 3.3V	Digital Vdd = 3.3V
DVdd2	I	Digital Vdd = 5.0V or 3.3V	Digital Vdd = 3.3V
DVss1	I	Digital Gnd	Digital Gnd
DVss2	I	Digital Gnd	Digital Gnd

3. AC-LINK

Below is the figure of the AC-Link point to point serial interconnect between the **STAC9780** and its companion controller. All digital audio streams and command/status information are communicated over this AC-Link. Please refer to the "Digital Interface" section 3 for details.

Figure 4. AC-Link to its companion controller

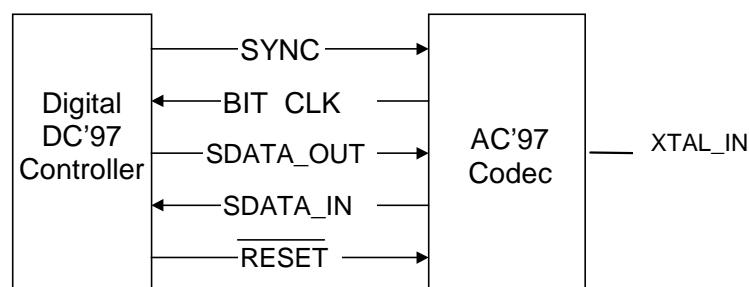

3.1 Clocking

STAC9780 derives its clock internally from an externally connected 24.576 MHz oscillator through the XTAL_IN pin. Synchronization with the AC'97 controller is achieved through the BIT_CLK pin at 12.288 MHz (half of crystal frequency). The **STAC9782** allows a 24.576 MHz crystal to be connected between XTAL_IN and XTAL_OUT.

The beginning of all audio sample packets, or “Audio Frames”, transferred over AC-Link is synchronized to the rising edge of the “SYNC” signal driven by the AC'97 controller. Data transitions on the AC-Link every rising edge of BIT_CLK, and is subsequently sampled by the receiving side on each immediately following falling edge of BIT_CLK.

3.2 Reset

There are 3 types of resets as detailed under “Timing Characteristics”.

1. a “cold” reset where all **STAC9780/82** logic and registers are initialized to their default state
2. a “warm” reset where the contents of the **STAC9780/82** register set are left unaltered
3. a “register” reset which only initializes the **STAC9780/82** registers to their default states

After signaling a reset to the **STAC9780/82**, the AC'97 controller should not attempt to play or capture audio data until it has sampled a “Codec Ready” indication via register 26h from the **STAC9780/82**.

For proper reset operation SDATA_OUT should be “0” during “cold” reset. See “Testability” section for more information.

4. DIGITAL INTERFACE

4.1 AC-Link Digital Serial Interface Protocol

The **STAC9780/82** communicates to the AC'97 controller via a 5-pin digital serial AC-Link interface, which is a bi-directional, fixed rate, serial PCM digital stream. All digital audio streams, commands and status information are communicated over this point-to-point serial interconnect. The AC-Link handles multiple inputs, and output audio streams, as well as control register accesses using a time division multiplexed (TDM) scheme. The AC'97 controller synchronizes all AC-Link data transaction. The following data streams are available on the **STAC9780/82**:

- | | | |
|--------------------------|-----------------------|---------------------------------------|
| • PCM Playback | 2 output slots | 2 Channel composite PCM output stream |
| • PCM Record data | 2 input slots | 2 Channel composite PCM input stream |
| • Control | 2 output slots | Control register write port |
| • Status | 2 input slots | Control register read port |

Synchronization of all AC-Link data transactions is handled by the AC'97 controller. The **STAC9780/82** drives the serial bit clock onto AC-Link. The AC'97 controller then qualifies with a synchronization signal to construct audio frames.

SYNC, fixed at 48 kHz, is derived by dividing down the serial bit clock (BIT_CLK). BIT_CLK, fixed at 12.288 MHz, provides the necessary clocking granularity to support 12, 20-bit outgoing and incoming time slots. AC-Link serial data is transitioned on each rising edge of BIT_CLK. The receiver of AC-Link data, **STAC9780/82**

for outgoing data and AC'97 controller for incoming data, samples each serial bit on the falling edges of BIT_CLK.

The AC-Link protocol provides for a special 16-bit (13-bits defined, with 3 reserved trailing bit positions) time slot (Slot 0) wherein each bit conveys a valid tag for its corresponding time slot within the current audio frame. A "1" in a given bit position of slot 0 indicates that the corresponding time slot within the current audio frame has been assigned to a data stream, and contains valid data. If a slot is "tagged" invalid, it is the responsibility of the source of the data (STAC9780/82 for the input stream, AC'97 controller for the output stream) to stuff all bit positions with 0's during that slot's active time.

SYNC remains high for a total duration of 16 BIT_CLKs at the beginning of each audio frame. The portion of the audio frame where SYNC is high is defined as the "Tag Phase". The remainder of the audio frame where SYNC is low is defined as the "Data Phase".

Additionally, for power savings, all clock, sync, and data signals can be halted.

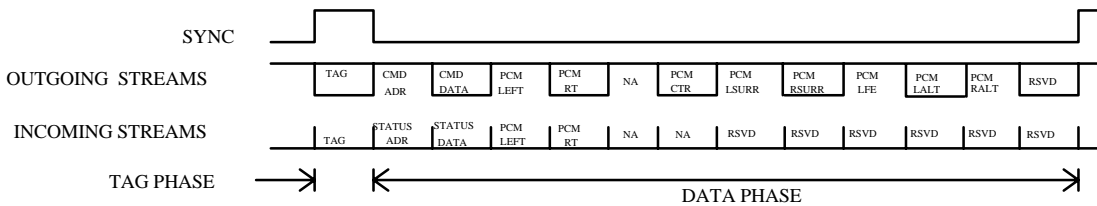
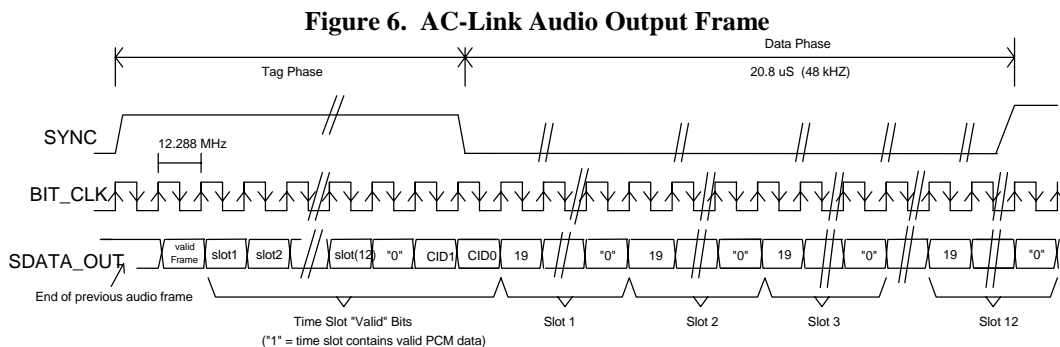

Figure 5. AC'97 Standard Bi-directional Audio Frame

4.2 AC-Link Audio Output Frame (SDATA_OUT)

The audio output frame data streams correspond to the multiplexed bundles of all digital output data targeting the STAC9780/82 DAC inputs, and control registers. Each audio output frame supports up to 12 20-bit outgoing data time slots. Slot 0 is a special reserved time slot containing 16 bits that are used for AC-Link protocol infrastructure.

Within slot 0, the first bit is a global bit (SDATA_OUT slot 0, bit 15) which flags the validity for the entire audio frame. If the "Valid Frame" bit is a 1, this indicates that the current audio frame contains at least one slot time of valid data. The next 12 bit positions sampled by the STAC9780/82 indicate which of the corresponding 12 time slots contain valid data. In this way data streams of differing sample rates can be transmitted across AC-Link at its fixed 48kHz audio frame rate. The following diagram illustrates the time slot based AC-Link protocol.



A new audio output frame begins with a low to high transition of SYNC. SYNC is synchronous to the rising edge of BIT_CLK. On the immediately following falling edge of BIT_CLK, the STAC9780/82 samples the assertion of SYNC. This following edge marks the time when both sides of AC-Link are aware of the start of a new audio

frame. On the next rising edge of BIT_CLK, the AC'97 controller transitions SDATA_OUT into the first bit position of slot 0 (Valid Frame bit). Each new bit position is presented to AC-Link on a rising edge of BIT_CLK, and subsequently sampled by the **STAC9780/82** on the following falling edge of BIT_CLK. This sequence ensures that data transitions, and subsequent sample points for both incoming and outgoing data streams are time aligned.

Figure 7. Start of an Audio Output Frame

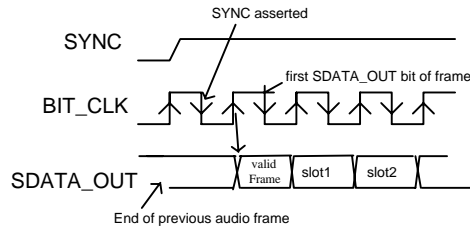

SDATA_OUT's composite stream is MSB justified (MSB first) with all non-valid slots' bit positions stuffed with 0's by the AC'97 controller. When mono audio sample streams are sent from the AC'97 controller it is necessary that BOTH left and right sample stream time slots be filled with the same data.

4.2.1.1 Slot 1: Command Address Port

The command port is used to control features, and monitor status (see Audio Input Frame Slots 1 and 2) of the **STAC9780/82** functions including, but not limited to, mixer settings, and power management (refer to the control register section of this specification).

The control interface architecture supports up to 64 16-bit read/write registers, addressable on even byte boundaries. Only the even registers (00h, 02h, etc.) are valid.

Audio output frame slot 1 communicates control register address, and write/read command information to the **STAC9780/82**.

Command Address Port bit assignments:

- Bit (19) Read/Write command (1= read, 0=write)
- Bit (18:12) Control Register Index (64 16-bit locations, addressed on even byte boundaries)
- Bit (11:0) Reserved (Stuffed with 0's)

The first bit (MSB) sampled by **STAC9780/82** indicates whether the current control transaction is a read or a write operation. The following 7 bit positions communicate the targeted control register address. The trailing 12 bit positions within the slot are reserved and must be stuffed with 0's by the AC'97 controller.

4.2.1.2 Slot 2: Command Data Port

The command data port is used to deliver 16-bit control register write data in the event that the current command port operation is a write cycle. (as indicated by Slot 1, bit 19)

- Bit (19:4) Control Register Write Data (Stuffed with 0's if current operation is a read)
- Bit (3 :0) Reserved (Stuffed with 0's)

If the current command port operation is a read then the entire slot time must be stuffed with 0's by the AC'97 controller.

4.2.1.3 Slot 3: PCM Playback Left Channel

Audio output frame slot 3 is the composite digital audio left playback stream. In a typical "Games Compatible" PC this slot is composed of standard PCM (.wav) output samples digitally mixed (by the

AC'97 controller or host processor) with music synthesis output samples. If a sample stream of resolution less than 20-bits is transferred, the AC'97 controller must stuff all trailing non-valid bit positions within this time slot with 0's.

4.2.1.4 Slot 4: PCM Playback Right Channel

Audio output frame slot 4 is the composite digital audio right playback stream. In a typical "Games Compatible" PC this slot is composed of standard PCM (.wav) output samples digitally mixed (by the AC'97 controller or host processor) with music synthesis output samples. If a sample stream of resolution less than 20-bits is transferred, the AC'97 controller must stuff all trailing non-valid bit positions within this time slot with 0's.

4.2.1.5 Slot 5: Reserved

Audio output frame slot 5 is reserved for modem operation and is not used by the **STAC9780/82**.

4.2.1.6 Slot 6: PCM Center Channel

Audio output frame slot 6 is not used by the **STAC9780/82**.

4.2.1.7 Slot 7: PCM Left Surround Channel

Audio output frame slot 7 is not used by the **STAC9780/82**.

4.2.1.8 Slot 8: PCM Right Surround Channel

Audio output frame slot 8 is not used by the **STAC9780/82**.

4.2.1.9 Slot 9: PCM Low Frequency Channel

Audio output frame slot 9 is not used by the **STAC9780/82**.

4.2.1.10 Slot 10: PCM Alternate Left

Audio output frame slot 10 is not used by the **STAC9780/82**.

4.2.1.11 Slot 11: PCM Alternate Right

Audio output frame slot 11 is not used by the **STAC9780/82**.

3.1.1.12 Slot 12: Reserved

Audio output frame slot 12 is reserved for modem operations and is not used by the **STAC9780/82**.

4.2.2 AC-Link Audio Input Frame (SDATA_IN)

The audio input frame data streams correspond to the multiplexed bundles of all digital input data targeting the AC'97 controller. As is the case for audio output frame, each AC-Link audio input frame consists of 12, 20-bit time slots. Slot 0 is a special reserved time slot containing 16 bits that are used for AC-Link protocol infrastructure.

Within slot 0 the first bit is a global bit (SDATA_IN slot 0, bit 15) which flags whether the **STAC9780/82** is in the "Codec Ready" state or not. If the "Codec Ready" bit is a 0, this indicates that **STAC9780/82** is not ready for normal operation. This condition is normal following the de-assertion of power on reset, for example, while **STAC9780/82**'s voltage references settle. When the AC-Link "Codec Ready" indicator bit is a 1, it indicates that the AC-Link and **STAC9780/82** control/status registers are in a fully operational state. The AC'97 controller must further probe the Powerdown Control Status Register index 26h (refer to Mixer Register section) to determine exactly which subsections, if any, are ready.

Prior to any attempts at putting **STAC9780/82** into operation the AC'97 controller should poll the first bit in the audio input frame (SDATA_IN slot 0, bit 15) for an indication that **STAC9780/82** has become "Codec Ready". Once the **STAC9780/82** is sampled "Codec Ready", the next 12 bit positions sampled by the AC'97 controller indicate which of the corresponding 12 time slots are assigned to input data streams, and that they contain valid data. The following diagram illustrates the time slot based AC-Link protocol.

Figure 8. STAC9780/82 Audio Input Frame

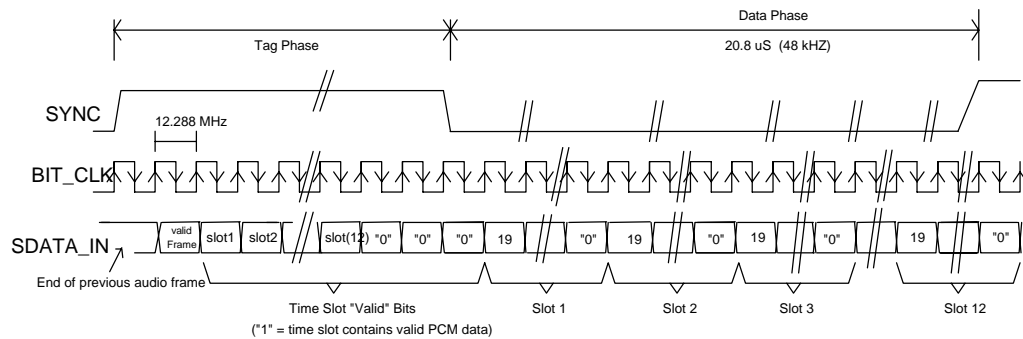

A new audio input frame begins with a low to high transition of SYNC. SYNC is synchronous to the rising edge of BIT_CLK. On the immediately following falling edge of BIT_CLK, **STAC9780/82** samples the assertion of SYNC. This falling edge marks the time when both sides of AC-Link are aware of the start of a new audio frame. On the next rising of BIT_CLK, the **STAC9780/82** transitions SDATA_IN into the first bit position of slot 0 ("Codec Ready" bit). Each new bit position is presented to AC-Link on a rising edge of BIT_CLK and subsequently sampled by the AC'97 controller on the following falling edge of BIT_CLK. This sequence ensures that data transitions, and subsequent sample points for both incoming and outgoing data streams are time aligned.

Figure 9. Start of an Audio Input Frame

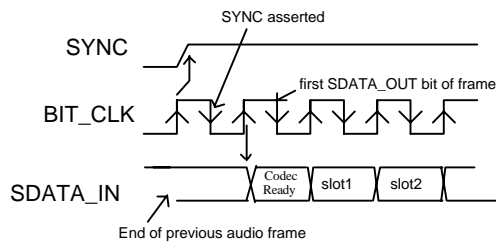

SDATA_IN's composite stream is MSB justified (MSB first) with all non-valid bit positions (for assigned and/or unassigned time slots) stuffed with 0's by **STAC9780/82**. SDATA_IN data is sampled on the falling edges of BIT_CLK.

4.2.2.1 Slot 1: Status Address Port

The status port is used to monitor status for **STAC9780/82** functions including, but not limited to, mixer settings, and power management.

Audio input frame slot 1's stream echoes the control register index, for historical reference, for the data to be returned in slot 2. (Assuming that slots 1 and 2 had been tagged "valid" by **STAC9780/82** during slot 0)

Status Address Port hit assignments:

Bit (19)	RESERVED	(Stuffed with 0)
Bit (18;12)	Control Register Index	(Echo of register index for which data is being returned)
Bit (11:0)	RESERVED	(Stuffed with 0's)

The first bit (MSB) generated by **STAC9780/82** is always stuffed with a 0. The following 7 bit positions communicate the associated control register address, and the trailing 12 bit positions are stuffed with 0's by **STAC9780/82**.

4.2.2.2 Slot 2: Status Data Port

The status data port delivers 16-bit control register read data.

Bit (19:4) Control Register Read Data (Stuffed with 0's if tagged "invalid")
 Bit (3 :0) RESERVED (Stuffed with 0's)

If Slot 2 is tagged "invalid" by **STAC9780/82**, then the entire slot will be stuffed with 0's.

4.2.2.3 Slot 3: PCM Record Left Channel

Audio input frame slot 3 is the left channel output of **STAC9780/82** input MUX, post-ADC. **STAC9780/82** ADCs are implemented to support 18-bit resolution.

STAC9780/82 outputs its ADC data (MSB first), and stuffs any trailing non-valid bit positions with 0's to fill out its 20-bit time slot.

4.2.2.4 Slot 4: PCM Record Right Channel

Audio input frame slot 4 is the right channel output of **STAC9780/82** input MUX, post-ADC.

STAC9780/82 outputs its ADC data (MSB first), and stuffs any trailing non-valid bit positions with 0's to fill out its 20-bit time slot.

4.2.2.5 Slots 5-12: Reserved

Audio input frame slots 5-12 are not used by the **STAC9780/82** and are always stuffed with 0's.

4.3 AC-Link Low Power Mode

The **STAC9780/82** AC-Link can be placed in the low power mode by programming register 26h to the appropriate value. Both BIT_CLK and SDATA_IN will be brought to, and held at a logic low voltage level. The AC'97 controller can wake up the **STAC9780/82** by providing the appropriate reset signals.

Figure 10. STAC9780/82 Powerdown Timing

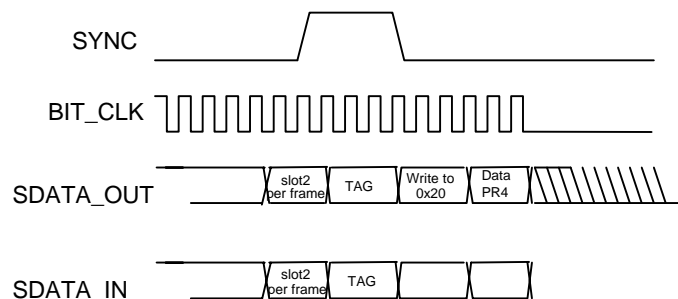

Note: BIT_CLK not to scale

BIT_CLK and SDATA_IN are transitioned low immediately (within the maximum specified time) following the decode of the write to the Powerdown Register (26h) with PR4. When the AC'97 controller driver is at the point where it is ready to program the AC-Link into its low power mode, slots (1 and 2) are assumed to be the only valid stream in the audio output frame (all sources of audio input have been neutralized).

The AC'97 controller should also drive SYNC and SDATA_OUT low after programming the **STAC9780/82** to this low power mode.

4.3.1 Waking up the AC-Link

Once the **STAC9780/82** has halted **BIT_CLK**, there are only two ways to “wake up” the AC-Link. Both methods must be activated by the AC'97 controller. The AC-Link protocol provides for a “Cold AC'97 Reset”, and a “Warm AC'97 Reset”. The current power down state would ultimately dictate which form of reset is appropriate. Unless a “cold” or “register” reset (a write to the Reset register) is performed, wherein the AC'97 registers are initialized to their default values, registers are required to keep state during all power down modes. Once powered down, re-activation of the AC-Link via re-assertion of the SYNC signal must not occur for a minimum of 4 audio frame times following the frame in which the power down was triggered. When AC-Link powers up it indicates readiness via the Codec Ready bit (input slot 0, bit 15).

Cold Reset - a cold reset is achieved by asserting **RESET#** for the minimum specified time. By driving **RESET#** low, **BIT_CLK**, and **SDATA_IN** will be activated, or re-activated as the case may be, and all **STAC9780/82** control registers will be initialized to their default power on reset values.

Note: **RESET#** is an asynchronous input. # denotes active low

Warm Reset - a warm reset will re-activate the AC-Link without altering the current **STAC9780/82** register values. A warm reset is signaled by driving **SYNC** high for a minimum of 1us in the absence of **BIT_CLK**.

Note: Within normal audio frames, **SYNC** is a synchronous input. However, in the absence of **BIT_CLK**, **SYNC** is treated as an asynchronous input used in the generation of a warm reset to the **STAC9780/82**.

5. STAC9780/82 MIXER

The **STAC9780/82** mixer is designed to the AC'97 specification to manage the playback and record of all digital and analog audio sources in the PC environment. These include:

- **System Audio:** digital PCM input and output for business, games and multimedia
- **CD/DVD:** analog CD/DVD-ROM Redbook audio with internal connections to Codec mixer
- **Mono microphone:** with programmable boost and gain
- **AUX/synth:** analog FM or wavetable synthesizer, or other internal source

Figure 11. STAC9780/82 Mixer Functional Diagram

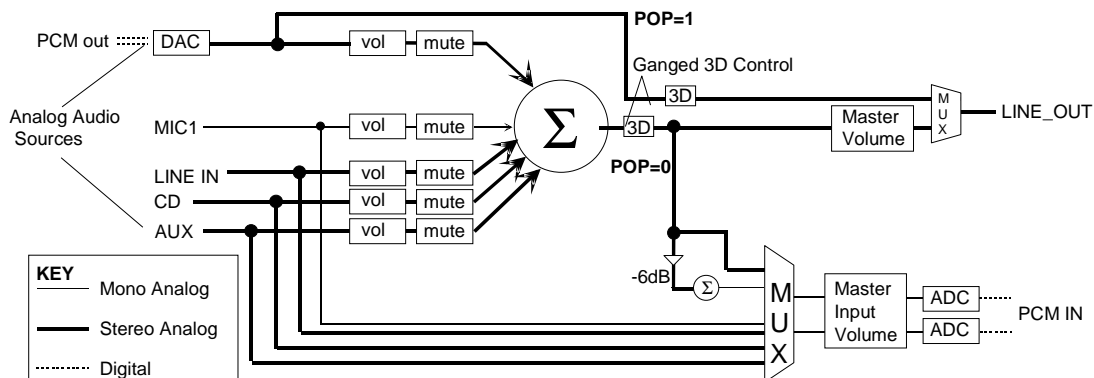

Table 6. Mixer Functional Connections

Source	Function	Connection
MIC1	desktop microphone	from mic jack
LINE_IN	external audio source	from line-in jack
CD	audio from CD-ROM	cable from CD-ROM
AUX	upgrade synth or other external source	internal connector
PCM out	digital audio output from AC'97 Controller	AC-Link
LINE_OUT	stereo mix of all sources	To output jack
PCM in	digital audio input to AC'97 Controller	AC-Link

5.1 Mixer Input

The mixer provides recording and playback of any audio sources or output mix of all sources. The STAC9780/82 supports the following input sources:

- any mono or stereo source
- mono or stereo mix of all sources
- 2-channel input w/mono output reference (mic + stereo mix)

* Note: any unused input pins should be tied together and connected to ground with a capacitor (0.1 uF suggested), except the MIC1 input which requires it's own 0.1 uF capacitor to ground if not used.

5.2 Mixer Output

The mixer generates a stereo mix of all sources for output to the LINE_OUT

5.3 Programming Registers:

Table 7. Programming Registers

REG #	NAME	D15	D14	D13	D12	D11	D10	D9	D8	D7	D6	D5	D4	D3	D2	D1	D0	DE-FAULT
00h	Reset	X	SE4	SE3	SE2	SE1	SE0	ID9	ID8	ID7	ID6	ID5	ID4	ID3	ID2	ID1	ID0	6940h
02h	Master Volume	Mute	X	X	ML4	ML3	ML2	ML1	ML0	X	X	X	MR4	MR3	MR2	MR1	MR0	8000h
0Eh	Mic Volume	Mute	X	X	X	X	X	X	X	X	20dB	X	GN4	GN3	GN2	GN1	GN0	8008h
10h	Line In Volume	Mute	X	X	GL4	GL3	GL2	GL1	GL0	X	X	X	GR4	GR3	GR2	GR1	GR0	8808h
12h	CD Volume	Mute	X	X	GL4	GL3	GL2	GL1	GL0	X	X	X	GR4	GR3	GR2	GR1	GR0	8808h
16h	AUX Volume	Mute	X	X	GL4	GL3	GL2	GL1	GL0	X	X	X	GR4	GR3	GR2	GR1	GR0	8808h
18h	PCM Out Volume	Mute	X	X	GL4	GL3	GL2	GL1	GL0	X	X	X	GR4	GR3	GR2	GR1	GR0	8808h
1Ah	Record Select	X	X	X	X	X	SL2	SL1	SL0	X	X	X	X	X	SR2	SR1	SR0	0000h
1Ch	Record Gain	Mute	X	X	X	GL3	GL2	GL1	GL0	X	X	X	X	GR3	GR2	GR1	GR0	8000h
20h	General Purpose	POP	X	3D	X	X	X	MIX	X	LPBK	X	X	X	X	X	X	X	0000h
22h	3D Control	X	X	X	X	X	X	X	X	X	X	X	X	DP3	DP2	X	X	0000h
26h	Powerdown Ctrl/Stat	X	PR6	PR5	PR4	PR3	PR2	PR1	PR0	X	X	X	X	REF	ANL	DAC	ADC	000Fh
6Ah	Revision Code	0	0	0	0	0	0	0	0	0	0	0	0	0	0	0	0	0000h
6Eh	Analog Special	X	X	X	X	X	X	X	X	X	X	X	X	X	X	DAC -6dB	ADC -6dB	0000h
7Ch	Vendor ID1	1	0	0	0	0	0	1	1	1	0	0	0	0	1	0	0	8384h
7Eh	Vendor ID2	0	1	1	1	0	1	1	0	0	0	0	0	0	0	0	0	7600h

Notes:

1. All registers not shown and bits containing an X are reserved.
2. Any reserved bits, marked X, are not writable, and read back as zeros.
3. If optional bits D13 and D5 of register 02h, or D5 of register 06h are set to 1, then the corresponding attenuation is set to 46dB and the register reads will produce 1Fh as a value for this attenuation/gain block.

5.3.1 Reset Register (Index 00h)

Writing any value to this register performs a register reset, which causes all registers to revert to their default values. Reading this register, returns the AC'97 ID code of the part.

5.3.2 Play Master Volume Registers (Index 02h and 06h)

These registers manage the output signal volumes. Register 02h controls the stereo master volume (both right and left channels) and register 06h controls the mono volume output. Each step corresponds to 1.5 dB. The MSB of the register is the mute bit. When this bit is set to 1 the level for that channel is set at $-\infty$ dB. ML5 through ML0 is for left channel level, MR5 through MR0 is for the right channel and MM5 through MM0 is for the mono out channel. If optional bits D13 and D5 of register 02h, or D5 of register 06h are set to 1, then the corresponding attenuation is set to 46dB and the register reads will produce 1Fh as a value for this attenuation/gain block.

The default value is 8000h for registers 02h and 06h which corresponds to 0 dB attenuation with mute on.

Table 8. Play Master Volume Register

Mute	Mx5...Mx0	Function	Range
0	00 0000	0dB Attenuation	Req.
0	01 1111	46.5 Attenuation	Req.
1	xx xxxx	∞ dB Attenuation	Req.

5.3.3 Analog Mixer Input Gain Registers (Index 0Ch - 18h)

The analog mixer input registers control the gain/attenuation for each of the analog inputs. Each step corresponds to approximately 1.5 dB. The MSB of the register is the mute bit. When the MSB is set to 1 the level for that channel is set at $-\infty$ dB. Register 0Eh (Mic Volume Register) has an extra bit which enables a 20dB gain boost. When bit 6 is set to 1, the 20 dB boost is on. The MIC Volume default value is 8008, which corresponds to 0 dB gain with mute on. The default value for the MONO and PHONE registers is 8008h, corresponding to 0dB gain with mute on. The default value for stereo registers is 8808h, corresponding to 0 dB gain with mute on.

Table 9. Analog Mixer Input Gain Register

Mute	Gx4...Gx0	Function
0	00000	+12 dB gain
0	01000	0 dB gain
0	11111	-34.5 dB gain
1	xxxxx	$-\infty$ dB gain

5.3.4 Record Select Control Register (Index 1Ah)

Used to select the record source independently for right and left. The default value is 0000h, which corresponds to MIC in. The VIDEO_IN and phone inputs have been removed from the STAC9780/82 and selecting options #2 and #7 will result in no record source.

Table 10. Record Select Control Registers

SR2...SR0	Right Record Source
0	MIC
1	CD IN (right)
2	No record source
3	AUX IN (right)
4	LINE_IN (right)
5	Stereo Mix (right)
6	Mono Mix
7	No record source

SL2...SL0	Left Record Source
0	MIC
1	CD IN (left)
2	No record source
3	AUX IN (left)
4	LINE_IN (left)
5	Stereo Mix (left)
6	Mono Mix
7	No record source

5.3.5 Record Gain Registers (Index 1Ch)

The 1Ch register adjusts the stereo input record gain. Each step corresponds to 1.5 dB. The 22.5 dB setting corresponds to 0F0Fh. The MSB of the register is the mute bit. When this bit is set to 1, the level for that channel(s) is set at $-\infty$ dB.

The default value is 8000h, which corresponds to 0 dB gain with mute on.

Table 11. Record Gain Registers

Mute	Gx3... Gx0	Function
0	1111	+22.5 dB gain
0	0000	0 dB gain
1	xxxx	$-\infty$ gain

5.3.6 General Purpose Register (Index 20h)

This register is used to control some miscellaneous functions. Below is a summary of each bit and its function. The LPBK bit enables loop-back of the ADC output to the DAC input without involving the AC-Link, allowing for full system performance measurements. The 3D bit enables or disables the SS3D speaker separation 3D enhancement. The POP bit allows the PCM DAC signal to pass directly to the output without first going through the mixer. This features allows independent playback and recording which facilitates the handling of local and remote analog sources in multi-codec systems as is often the case in docking station applications. Note that the 3D can remain active when the mixer bypass mode is active. If the 3D is not desired during mixer bypass operations it should also be disabled.

Table 12. General Purpose Register

Bit	Function
POP	PCM Mixer bypass 0 = normal mode, 1 = PCM DAC output bypassed directly to the outputs
3D	3D Stereo Enhancement 0 = off, 1 = on
MIX	Mono output select 0 = Mix, 1 = MIC
LPBK	ADC/DAC loopback mode

5.3.7 3D Control Register (Index 22h)

This register is used to control the 3D stereo enhancement function, *SigmaTel Surround 3D (SS3D)*, built into the codec. *SS3D* provides for a wider soundstage and speaker separation for 2-speaker arrangements. Register bits, DP3-DP2 are used to control the separation ratios in the 3D control for LINE_OUT. The 3D bit in the general purpose register (register 20h bit D13) must be set to 1 to enable SS3D functionality and for the bits in 22h to take effect.

Table 13. 3D Control Registers

DP3..DP0	LINE_OUT SEPARATION RATIO
00XX	0 (Off)
01XX	3 (Low)
10XX	4.5 (Med.)
11XX	6 (High)

The three separation ratios are implemented as shown above. The separation ratio defines a series of equations that determine the amount of depth difference (High, Medium, and Low) perceived during two-channel playback. The ratios provide an indication of how much soundstage increase can be expected.

5.3.8 Powerdown Control/Status Register (Index 26h)

This read/write register is used to program powerdown states and monitor subsystem readiness. The lower half of this register is read only status, a "1" indicating that the subsection is "ready". *Ready* is defined as the subsection's ability to perform in its nominal state. When this register is written, bits D7:D0 will not be affected. Bit D15 controls the External Amplifier Power Down pin.

When the AC-Link “Codec Ready” indicator bit (SDATA_IN slot 0, bit 15) is a 1, it indicates that the AC-Link and AC'97 control and status registers are in a fully operational state. The AC'97 controller must further probe this Powerdown Control/Status Register (D3:D0) to determine exactly which subsections, if any are ready.

Table 14. Powerdown Status Registers

BIT	FUNCTION
REF	Indicates VREF is at nominal level
ANL	Analog mixers, etc. ready
DAC	DAC section ready to playback data
ADC	ADC section ready to playback data

5.3.9 Revision Code Register (Index 6Ah)

The device Revision register (index 6Ah) contains a software readable revision-specific code used to identify performance, architectural, or software differences between various device revisions. Bits 7:0 of the Revision register are user readable; bits 15:8 are not used at this time and will return zeros when read. The lower order bits of the Revision Register (bits 7:0) are initially set to 00h, and will change if there are any **STAC9780/82** metal revisions. This value can be used by the audio driver, or mini-port driver in the case of WIN98[®] WDM, to adjust software functionality matching the feature-set of the **STAC9780/82**. This will allow the software driver to identify any required operational differences between the existing **STAC9780/82** and any future versions.

5.3.10 Analog Special Register (Index 6Eh)

The Analog Special Register has two read/write bits used to control two functions specific to the **STAC9780/82**. DAC -6dB is used to program the DAC outputs to a -6dB signal level relative to the value of gain already programmed. Similarly, ADC -6dB attenuates any signal input to the ADC by 6dB. This second function is very useful in applications with greater than 1Vrms input levels, as is the case with many CDROMs.

5.3.11 Vendor ID1 and ID2 (Index 7Ch and 7Eh)

These two registers contain four 8-bit ID codes. The first three codes have been assigned by Microsoft using their Plug and Play Vendor ID methodology. The fourth code is a *SigmaTel*, Inc. assigned code identifying the **STAC9780/82**. The ID1 register (index 7Ch) contains the value 8384h, which is the first (83h) and second (84h) characters of the Microsoft[®] ID code. The ID2 register (index 7Eh) contains the value 7600h, which is the third (76h) of the Microsoft[®] ID code, and 00h which is the **STAC9780/82** ID code.

6. Low Power Modes

The **STAC9780/82** is capable of operating at reduced power when no activity is required. The state of power down is controlled by the Powerdown Register (26h). There are 7 separate power down commands. The power down options are listed in Table 19. The first three bits, PR0..PR2, can be used individually or in combination with each other, controlling power distribution to the ADC's, DAC's and Mixer. The last analog power control bit, PR3, affects analog bias and reference voltages, and can only be used in combination with PR1, PR2, and PR3. PR3 essentially removes power from all analog sections of the codec, and is generally only asserted when the codec will not be needed for long periods. PR0 and PR1 control the PCM ADC's and DAC's only. PR2 and PR3 do not need to be "set" before a PR4, but PR0 and PR1 must be "set" before PR4.

Table 15. Low Power Modes

PRx Bits	Function
PR0	PCM in ADC's & Input Mux Powerdown
PR1	PCM out DACs Powerdown
PR2	Analog Mixer powerdown (Vref still on)
PR3	Analog Mixer powerdown (Vref off)
PR4	Digital Interface (AC-Link) powerdown (extnl clk off)
PR5	Internal Clk disable
PR6	N/A

Figure 12. Example of STAC9780/82 Powerdown/Powerup flow

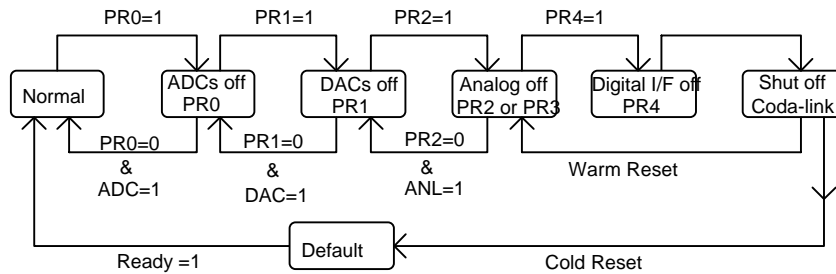

The above figure illustrates one example procedure to do a complete powerdown of **STAC9780/82**. From normal operation, sequential writes to the Powerdown Register are performed to power down **STAC9780/82** a piece at a time. After everything has been shut off, a final write (of PR4) can be executed to shut down the AC-Link. The part will remain in sleep mode with all its registers holding their static values. To wake up, the AC'97 controller will send an extended pulse on the sync line, issuing a warm reset. This will restart the AC-Link (resetting PR4 to zero). The **STAC9780/82** can also be woken up with a cold reset. A cold reset will reset all of the registers to their default states. When a section is powered back on, the Powerdown Control/Status register (index 26h) should be read to verify that the section is ready (stable) before attempting any within that section.

Figure 13. STAC9780/82 Powerdown/Powerup flow with analog still alive

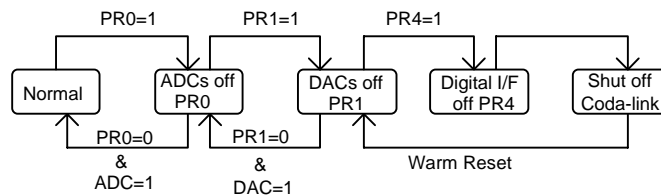

The above figure illustrates a state when all the mixers should work with the static volume settings that are contained in their associated registers. This configuration can be used when playing a CD (or external LINE_IN source) through **STAC9780/82** to the speakers, while most of the system in low power mode. The procedure for this follows the previous example except that the analog mixer is never shut down.

7. TESTABILITY

The STAC9780/82 has two test modes. One is for ATE in-circuit test and the other is restricted for *SigmaTel's* internal use. STAC9780/82 enters the ATE in circuit test mode if SDATA_OUT is sampled high at the trailing edge of RESET#. Once in the ATE test mode, the digital AC-Link outputs (BIT_CLK and SDATA_IN) are driven to a high impedance state. This allows ATE in-circuit testing of the AC'97 controller. This case will never occur during standard operating conditions. Once either of the test mode have been entered, the STAC9780/82 must be issued another reset with the SDATA_OUT signal held low to return to the normal operating mode. The SYNC triggered ATE test mode is not implemented on the STAC9780/82.

8. AC TIMING CHARACTERISTICS

($T_{\text{ambient}} = 25\text{ }^{\circ}\text{C}$, $AV_{\text{dd}} = 5.0\text{V} \pm 5\%$, $DV_{\text{dd}} = 5.0\text{V}$ or $3.3\text{V} \pm 5\%$, $Av_{\text{ss}} = DV_{\text{ss}} = +0\text{V}$; 50pF external load)

8.1 Cold Reset

Figure 14. Cold Reset

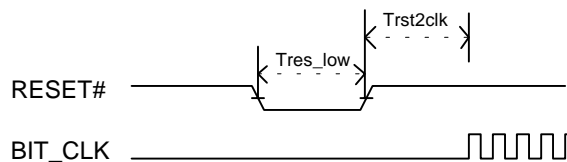

Table 16. Cold Reset

PARAMETER	SYMBOL	MIN	TYP	MAX	UNITS
RESET# active low pulse width	$T_{\text{res_low}}$	1.0	-	-	us
RESET# inactive to BIT_CLK startup delay	T_{rst2clk}	162.8	-	-	ns

denotes active low.

8.2 Warm Reset

Figure 15. Warm Reset

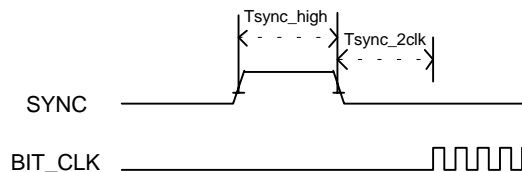

Table 17. Warm Reset

PARAMETER	SYMBOL	MIN	TYP	MAX	UNITS
SYNC active high pulse width	Tsync_high	1.0	1.3	-	us
SYNC inactive to BIT_CLK startup delay	Tsync2clk	162.8	-	-	ns

8.3 Clocks

Figure 16. Clocks

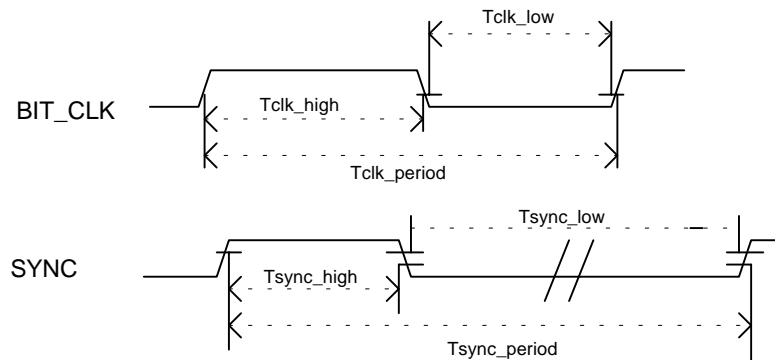

Table 18. Clocks

PARAMETER	SYMBOL	MIN	TYP	MAX	UNITS
BIT_CLK frequency		-	12.288	-	MHz
BIT_CLK period	Tclk_period	-	81.4	-	ns
BIT_CLK output jitter		-	-	750	ps
BLT_CLK high pulsewidth (note 1)	Tclk_high	36	40.7	45	ns
BIT_CLK low pulse width (note 1)	Tclk_low	36	40.7	45	ns
SYNC frequency		-	48.0	-	kHz
SYNC period	Tsync_period	-	20.8	-	us
SYNC high pulse width	Tsync_high	-	1.3	-	us
SYNC low_pulse width	Tsync_low	-	19.5	-	us

Notes: 1) Worst case duty cycle restricted to 44/56.

8.4 Data Setup and Hold

(50pF external load)

Figure 17. Data Setup and Hold

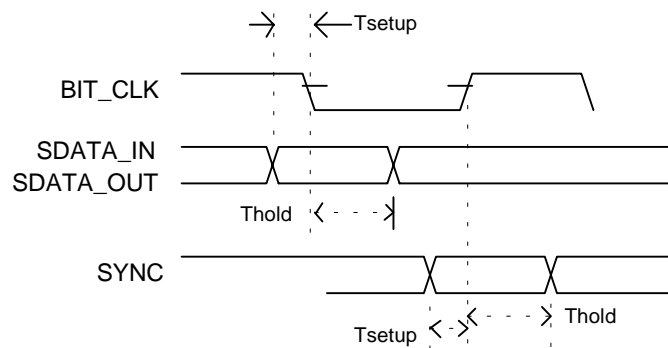

Table 19. Data Setup and Hold

Parameter	Symbol	Min	Typ	Max	Units
Setup to falling edge of BIT_CLK	Tsetup	10.0	-	-	ns
Hold from falling edge of BIT_CLK	Thold	1.0	-	-	ns

Note 1: Setup and hold time parameters for SDATA_IN are with respect to the AC'97 controller.

8.5 Signal Rise and Fall Times

(50pF external load; from 10% to 90% of V_{dd})

Figure 18. Signal Rise and Fall Times

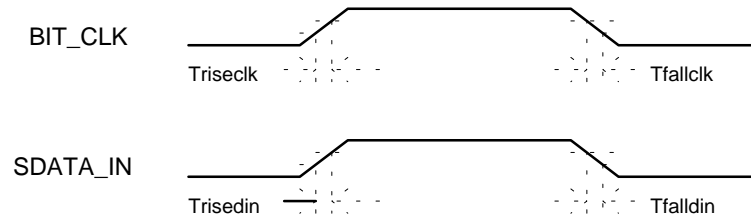

Table 20. Signal Rise and Fall Times

PARAMETER	SYMBOL	MIN	TYP	MAX	UNITS
BIT_CLK rise time	Triseclk	2	-	6	ns
BIT_CLK fall time	Tfallclk	2	-	6	ns
SDATA_IN rise time	Trisedin	2	-	6	ns
SDATA_IN fall time	Tfalldin	2	-	6	ns

8.6 AC-Link Low Power Mode Timing

Figure 19. AC-Link Low Power Mode Timing

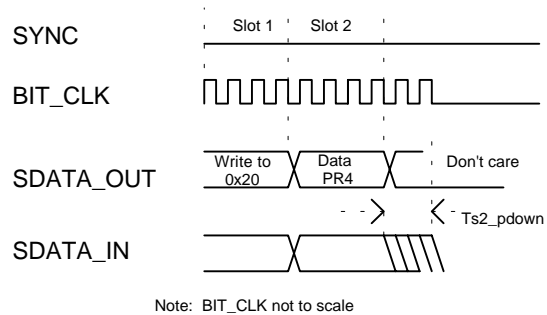

Table 21. AC-Link Low Power Mode Timing

PARAMETER	SYMBOL	MIN	TYP	MAX	UNITS
End of Slot 2 to BIT_CLK, SDATA_IN low	Ts2_pdown	-	-	1.0	us

8.7 ATE Test Mode

Figure 20. ATE Test Mode

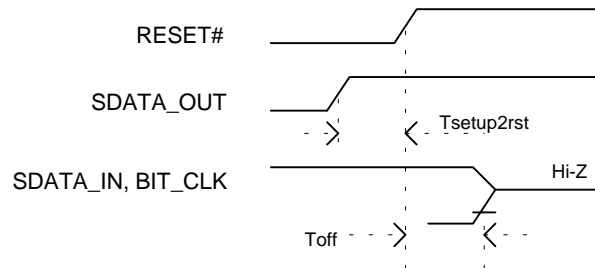

Table 22. ATE Test Mode

PARAMETER	SYMBOL	MIN	TYP	MAX	UNITS
Setup to trailing edge of RESET# (also applies to SYNC)	Tsetup2rst	15.0	-	-	ns
Rising edge of RESET# to Hi-Z delay	Toff	-	-	25.0	ns

Notes:

1. All AC-Link signals are normally low through the trailing edge of RESET#. Bringing SDATA_OUT high for the trailing edge of RESET# causes **STAC9780/82**'s AC-Link outputs to go high impedance which is suitable for ATE in circuit testing.
2. Once either of the two test modes have been entered, the **STAC9780/82** must be issued another RESET# with all AC-Link signals low to return to the normal operating mode.

denotes active low.

9. ELECTRICAL SPECIFICATIONS:

9.1 Absolute Maximum Ratings:

Voltage on any pin relative to Ground	V _{ss} - 0.3V TO V _{dd} + 0.3V
Operating Temperature	0 °C TO 70 °C
Storage Temperature	-55 °C TO +125 °C
Soldering Temperature	260 °C FOR 10 SECONDS
Output Current per Pin	± 4 mA except V _{refout} = ± 5mA

9.2 Recommended Operating Conditions

Table 23. Operating Conditions

PARAMETER	MIN	TYP	MAX	UNITS	
Power Supplies	+ 3.3V Digital	3.135	3.3	3.465	V
	+ 5V Digital	4.75	5	5.25	V
	+ 5V Analog	4.75	5	5.25	V
Ambient Temperature	0	-	70	°C	

SigmaTel reserves the right to change specifications without notice.

9.3 Power Consumption

Table 24. Power Consumption

PARAMETER	MIN	TYP	MAX	UNITS
Digital Supply Current	+ 5V Digital	45		mA
	+ 3.3V Digital	30		mA
Analog Supply Current	+ 5V Analog	40		mA
Power Down Status				
PR0	+5V Analog Supply Current	30		mA
PR1	+5V Analog Supply Current	25		mA
PR2	+5V Analog Supply Current	20		mA
PR3	+5V Analog Supply Current	0.1		mA
PR4	+3.3V Digital Supply Current	0.1		mA
PR4	+5V Digital Supply Current	0.1		mA
PR5	No effect			

9.4 AC-Link Static Digital Specifications

($T_{\text{ambient}} = 25\text{ }^{\circ}\text{C}$, $DV_{\text{dd}} = 5.0\text{V}$ or $3.3\text{V} \pm 5\%$, $AV_{\text{ss}}=DV_{\text{ss}}=0\text{V}$; 50pF external load)

Table 25. AC-Link Static Specifications

PARAMETER	SYMBOL	MIN	TYP	MAX	UNITS
Input Voltage Range	V_{in}	-0.30		$DV_{\text{dd}} + 0.30$	V
Low level input range	V_{il}	-	-	$0.35 \times DV_{\text{dd}}$	V
High level input voltage	V_{ih}	$0.40 \times DV_{\text{dd}}$	-	-	V
High level output voltage	V_{oh}	$0.90 \times DV_{\text{dd}}$	-	-	V
Low level output voltage	V_{ol}	-	-	$0.1 \times DV_{\text{dd}}$	V
Input Leakage Current (AC-Link inputs)	-	-10	-	10	μA
Output Leakage Current (Hi-Z'd AC-Link outputs)	-	-10	-	10	μA
Output buffer drive current	-	-	4		mA

9.5 STAC9780/82 +5V Analog Performance Characteristics

($T_{\text{ambient}} = 25\text{ }^{\circ}\text{C}$, $AV_{\text{dd}} = 5.0\text{V} \pm 5\%$, $DV_{\text{dd}} = 3.3\text{V} \pm 5\%$, $AV_{\text{ss}}=DV_{\text{ss}}=0\text{V}$; 1 kHz input sine wave; Sample Frequency = 48 kHz; 0 dB = 1 Vrms, 10K Ω /50pF load, Testbench Characterization BW: 20 Hz – 20 kHz, 0 dB settings on all gain stages)

Table 26. Analog Performance Characteristics

PARAMETER	MIN	TYP	MAX	UNITS
Full Scale Input Voltage:				
Line Inputs	-	1.0	-	Vrms
Mic Input ¹	-	0.1	-	Vrms
Full Scale Output Voltage:				
Line Output 5V	-	1.0	-	Vrms
Analog S/N:				
CD to LINE_OUT 5V	90	98	-	dB
Other to LINE_OUT 5V	-	98	-	dB
Analog Frequency Response ²	20	-	20,000	Hz
Digital S/N ³				
D/A 5V	85	96	-	dB
A/D 5V	75	87	-	dB
Total Harmonic Distortion:				
Line Output ⁴	-	-	0.02	%
D/A & A/D Frequency Response ⁵	20	-	19,200	Hz
Transition Band	19,200	-	28,800	Hz
Stop Band	28,800	-	∞	Hz
Stop Band Rejection ⁶	+85	-	-	dB
Out-of-Band Rejection ⁷	-	+40	-	dB
Group Delay	-	-	1	ms
Power Supply Rejection Ratio (1kHz)	-	+40	-	dB
Crosstalk between Input channels	-	-	-70	dB
Spurious Tone Rejection	-	+100	-	dB

Attenuation, Gain Step Size	-	1.5	-	dB
Input Impedance	10	-	-	K Ω
Input Capacitance	-	15	-	PF
Interchannel Gain Mismatch ADC			0.5	dB
Interchannel Gain Mismatch DAC		-	0.5	dB
Gain Drift		100		ppm/deg. C
DAC Offset Voltage		10	50	mV
Deviation from Linear Phase			1	degree
External Load Impedance	10			K ohm
Mute Attenuation (Vrms input)	90	96		dB

Notes:

1. With +20 dB Boost on, 1.0Vrms with Boost off
2. ± 1 dB limits
3. The ratio of the rms output level with 1 kHz full scale input to the rms output level with all zeros into the digital input. Measured "A weighted" over a 20 Hz to a 20 kHz bandwidth. (AES17-1991 Idle Channel Noise or EIAJ CP-307 Signal-to-noise Ratio).
4. 0 dB gain, 20 kHz BW, 48 kHz Sample Frequency
5. ± 0.25 dB limits
6. Stop Band rejection determines filter requirements. Out-of-Band rejection determines audible noise.
7. The integrated Out-of-Band noise generated by the DAC process, during normal PCM audio playback, over a bandwidth 28.8 to 100 kHz, with respect to a 1 Vrms DAC output.

Appendix A

SPLIT INDEPENDENT POWER SUPPLY OPERATION

In PC applications, one power supply input to the **STAC9780/82** may be derived from a supply regulator (as shown in Figure 3) and the other directly from the PCI power supply bus. When power is applied to the PC, the regulated supply input to the IC will be applied some time delay after the PCI power supply. Without proper on-chip partitioning of the analog and digital circuitry, some manufacturer's codecs would be subject to on-chip SCR type latch-up.

SigmaTel's **STAC9780/82** specifically allows power-up sequencing delays between the analog (AVddx) and digital (VDddx) supply pins. These two power supplies can power-up independently and at different rates with no adverse effects to the codec. The IC is designed with independent analog and digital circuitry that prevents on-chip SCR type latch-up.

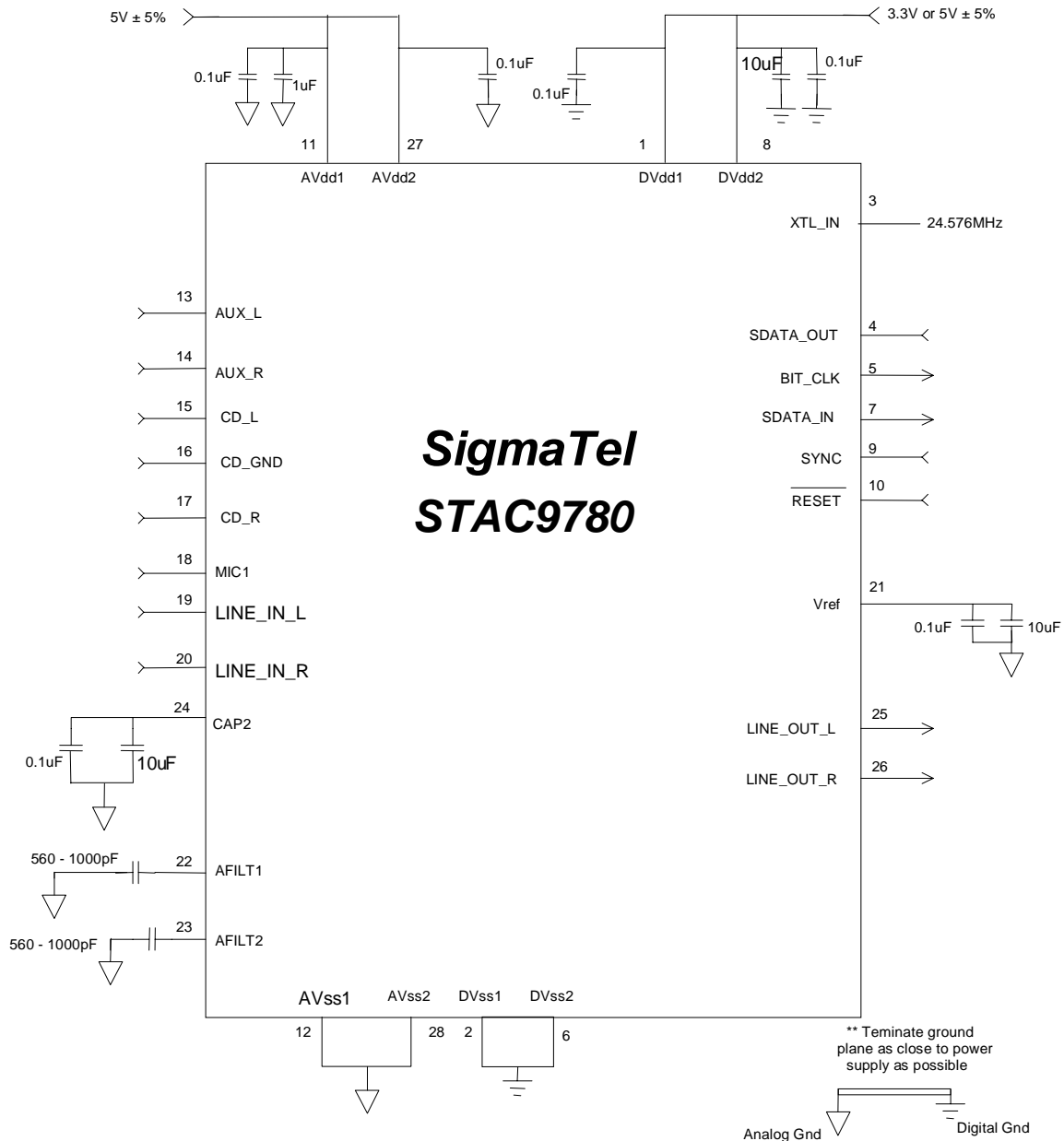

Appendix B

+5.0V/+3.3V POWER SUPPLY OPERATION NOTES

The **STAC9780/82** is capable of operating from a single 5V supply connected to both DVdd and Avdd. When operating with a +5V digital supply, all digital AC-Link interface signals should be at a 5V level. If digital interface signals below 5V are used with a +5V digital supply, then appropriate level shifting circuitry may be needed to ensure adequate digital noise immunity.

The **STAC9780/82** can also operate from a +3.3V digital supply connected to DVdd while maintaining a 5V analog supply on AVdd. On-chip level shifters ensure accurate logic transfers between the analog and digital portions of the **STAC9780/82**. If digital interface signals above +3.3V are used (i.e. a +5V AC-Link interface), appropriate level shifting circuitry must be provided to prevent on-chip ESD protection diodes from turning on. (See Appendixes A concerning SPLIT INDEPENDENT POWER SUPPLY OPERATION).

***Always operate the STAC97xx digital supply from the same supply voltage as the digital controller supply.**

***All the analog inputs must be ac-coupled with a capacitor of 0.33 uF or greater. It is recommended that a resistor of about 47K Ω be connected from the signal side of the capacitor to analog GND as shown below.**

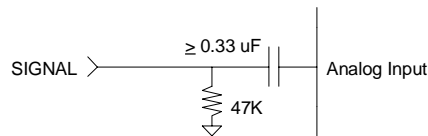

***All the analog outputs must be ac-coupled. If an external amplifier is used, make sure that the input impedance of the amplifier is at least 10K Ω and use an ac-coupling capacitor of +2 uF or greater to maintain the minimum PC99 20 Hz low-frequency bandwidth.**

- NOTES -

- NOTES -

For more information, please contact:

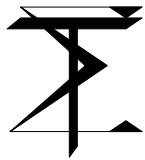

SigmaTel, Inc.

**6101 W. Courtyard Dr., Bldg. 1, Suite 100
Austin, Texas 78730**

Tel (512) 343-6636, Fax (512) 343-6199

email: sales@sigmatel.com

Homepage: www.sigmatel.com